

1 0 0 9 1 7 7 7 - X 0 E - X X X L F

8-COLUMN DIFFERENTIAL SIGNAL

LEAD-FREE DESIGNATION ONLY WITH APPLICABLE PLATING CODES

LETTER	PERFORMANCE-BASED PLATING (SEE NOTE 2)	
	TARGET APPLICATION	LEAD-FREE (LF)
B	TELCORDIA CO	NO
C	TELCORDIA UE	NO
D	TELCORDIA CO	YES
E	TELCORDIA UE	YES

NUMBER	PIN STYLE, HEIGHT
0	STANDARD GUIDE PIN MACHINED, 31.6mm
4	STANDARD GUIDE PIN MACHINED, 25.7mm

MODULE DESCRIPTION	LETTER DESIGNATION REPRESENTED IN DASH NUMBER										BASE MODULE
LEFT POLARIZING GUIDANCE MODULE (SEE SHEET 3)	J	A	B	C	D	E	F	G	H		
RIGHT POLARIZING GUIDANCE MODULE (SEE SHEET 4)	Y	P	Q	R	S	T	U	V	W		
OPEN MODULE (TWO WALL) (SEE SHEET 2)	0 (ZERO)										
LEFT WALL MODULE (SEE SHEET 5)	L										
RIGHT WALL MODULE (SEE SHEET 6)	M										
FOUR WALL MODULE (SEE SHEET 7)	1										

NUMBER	CONTACT MATING WIPE LENGTH		COMPLIANT PIN DRILL SIZE
	SIGNAL	WIDE GROUND	
1	2	4	Ø0.55 [0.0217"]
2	3	4	Ø0.55 [0.0217"]
3	2	4	Ø0.45 [0.0177"]
4	3	4	Ø0.45 [0.0177"]
5	2	3	Ø0.55 [0.0217"]
6	3	3	Ø0.55 [0.0217"]
7	2	3	Ø0.45 [0.0177"]
8	3	3	Ø0.45 [0.0177"]

	GROUNDED	UNGROUNDED
FINISHED	Ø2.35-2.55	Ø2.35-2.55
PAD	Ø5.50	N/A
PLATED	YES	NO
DRILL (mm/in)	2.58 / .1015	2.44 / .096

SCREW P/N	DESCRIPTION	BOARD THICKNESS
10091790-002LF	#2-56 X .375" PHILLIPS PANHEAD W/SQ CONICAL WASHER	1.60 - 5.00
10091790-003LF	#2-56 X .500" PHILLIPS PANHEAD W/SQ CONICAL WASHER	5.00 - 10.00

spec ref	SEE NOTES	dr	Jim Swain	2009/07/07	projection	MM	size	A2	scale	4:1
tolerance std	ASME Y14.5	eng	Sandar Soe	2015/06/29	chr		ecn no	ELX-S-21214-1	rel level	Released
surface	linear	appr	Chen-Hong Tan	2015/09/30	product family	XCede	rel level	Released	sig no	10091777
ASME Y14.5	angular	0°	±°	0.X ±0.2	0.XX ±0.10	0.XXX ±0.050	www.fci.com	cat. no.	SEE P/N TREE	Product - Customer Drw
								MODULE ASSEMBLY VERTICAL HEADER, 8-COLUMN, 4-PAIR	rev F	sheet 1 of 8

Copyright FCI. FCI

OPEN (2-WALL) MODULE

SEE NOTE 8

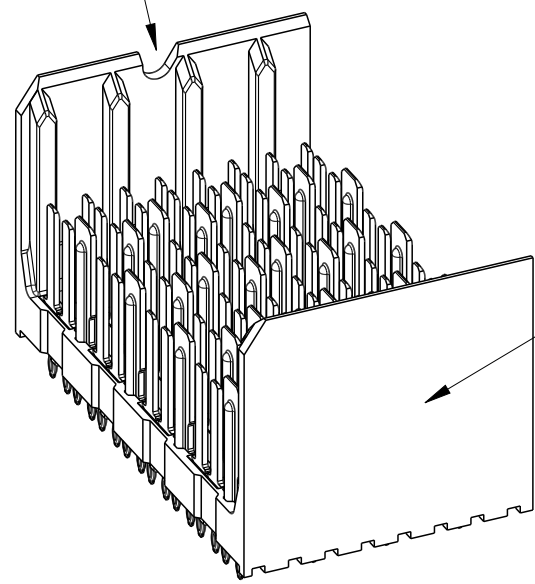

SEE NOTE 5

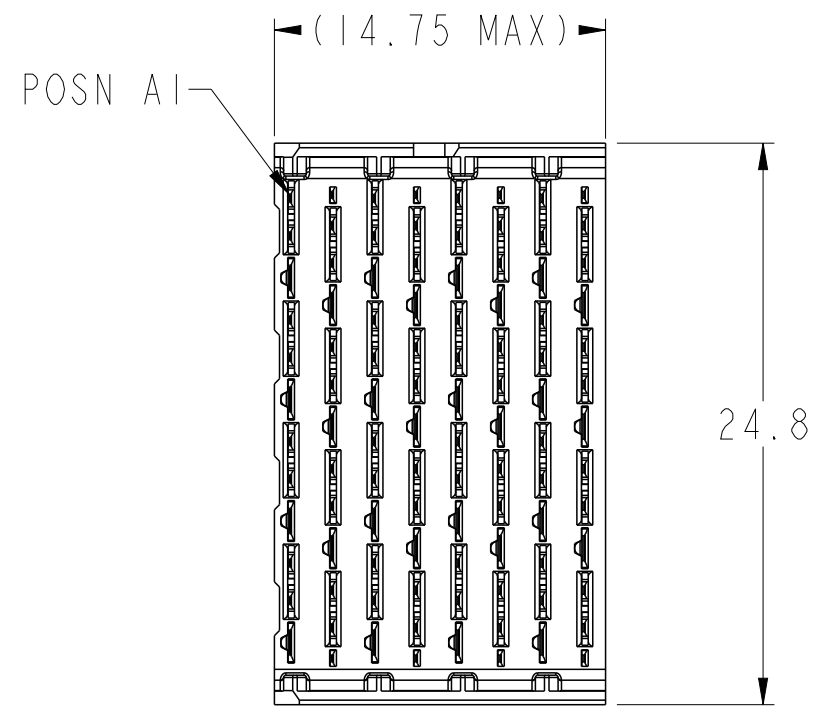

2.54
TO TOP SURFACE
OF DAUGHTERCARD

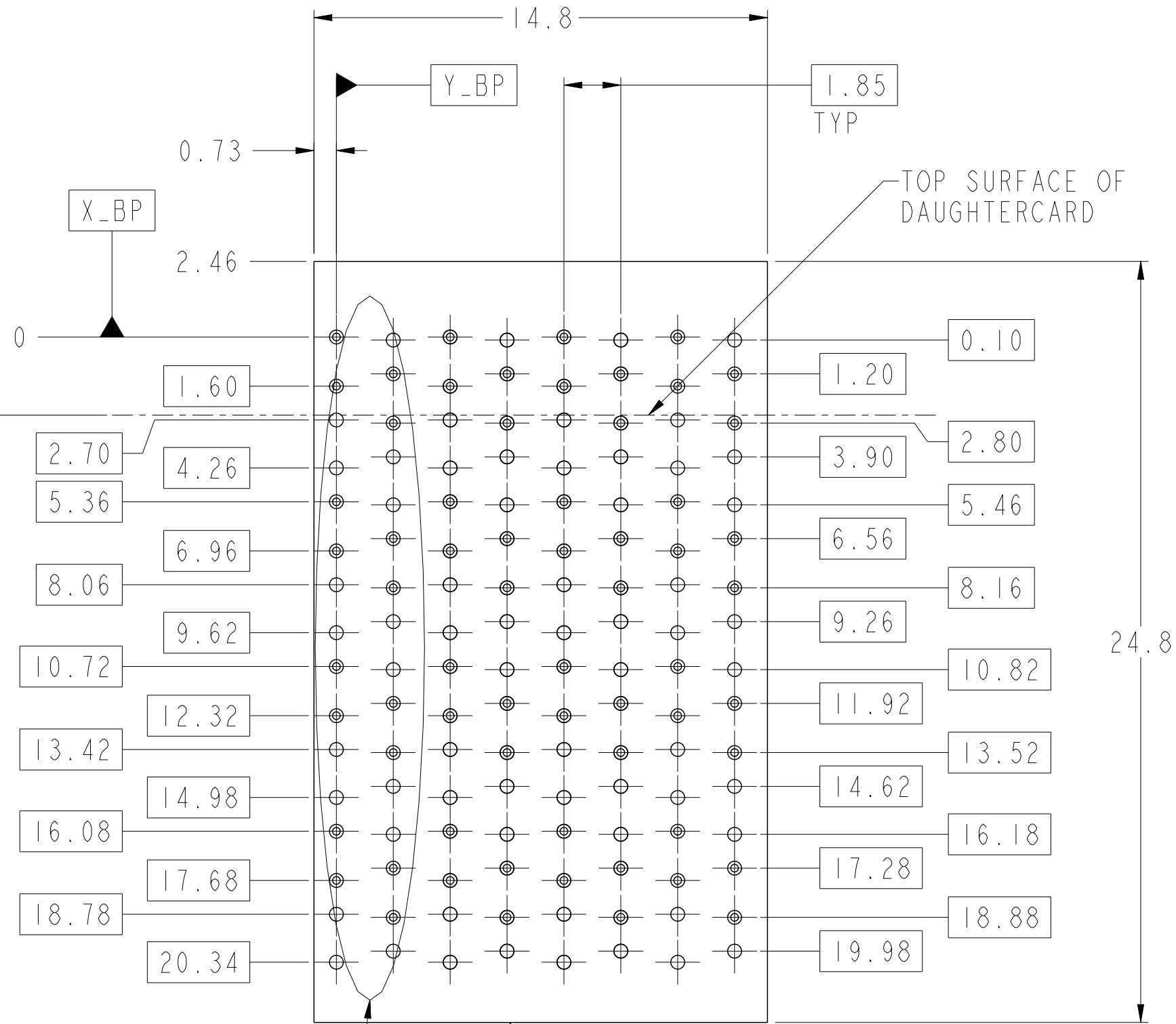

SEE DETAIL A
(SHEET 8)

NOMINAL MODULE OUTLINE

PCB HOLE PATTERN
COMPONENT SIDE
SCALE 6:1

- 6.2 (4MM WIPE WIDE GROUNDS)
 - 5.2 (3MM WIPE WIDE GROUNDS)
 - 5.2 (3MM SMALL END GROUNDS)
 - 5.2 (3MM WIPE SIGNALS)
 - 4.2 (2MM WIPE SIGNALS)
- SEE P/N TREE

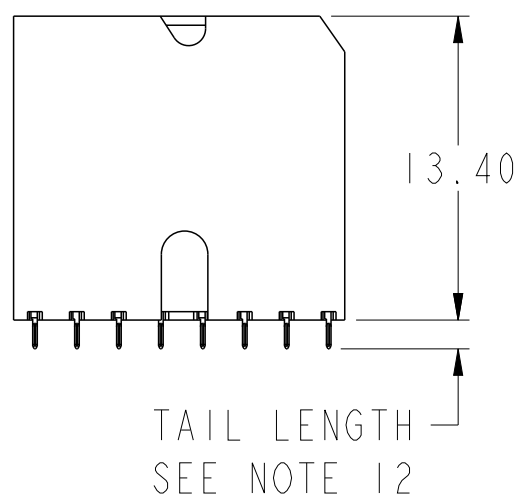
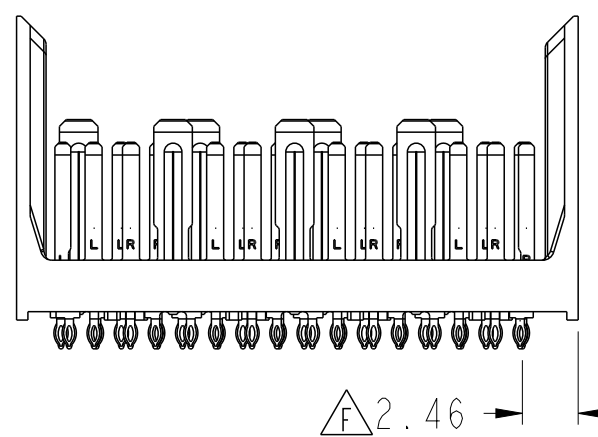
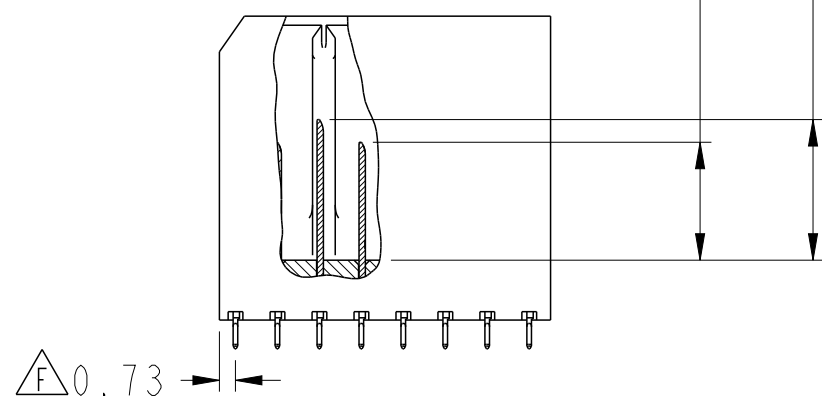

spec ref	SEE NOTES	dr	Jim Swain	2009/07/07	projection	MM	size	A2	scale	4:1
tolerance std	ASME Y14.5	eng	Sandar Soe	2015/06/29	chr	-	ecn no	ELX-S-21214-1	rel level	Released
surface	✓	appr	Chen-Hong Tan	2015/09/30	product family	XCede	rel level	Released	rev	F
ASME Y14.5	linear	0.X	±0.2	0.XX	±0.10	0.XXX	±0.050	angular	0°	±°
				MODULE ASSEMBLY VERTICAL HEADER, 8-COLUMN, 4-PAIR		cat. no. SEE P/N TREE		Product - Customer Drw		sheet 2 of 8

LEFT POLARIZING/GUIDE MODULE

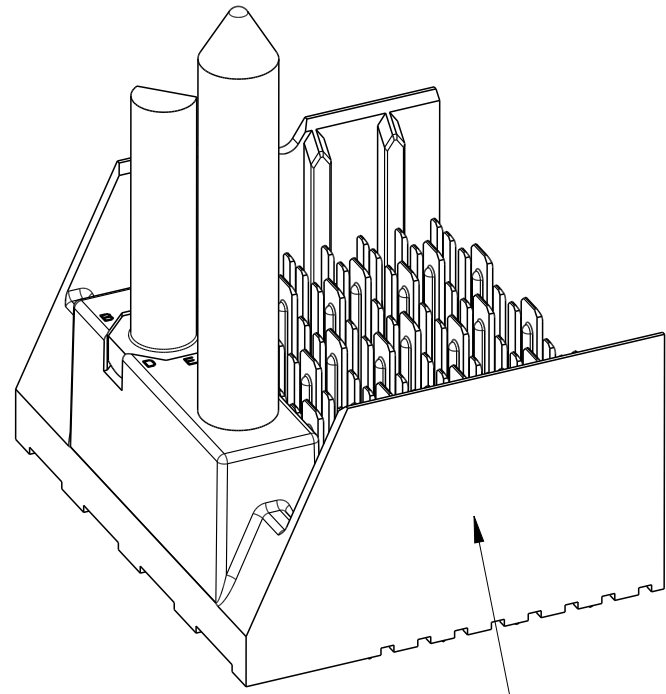

SEE NOTE 5

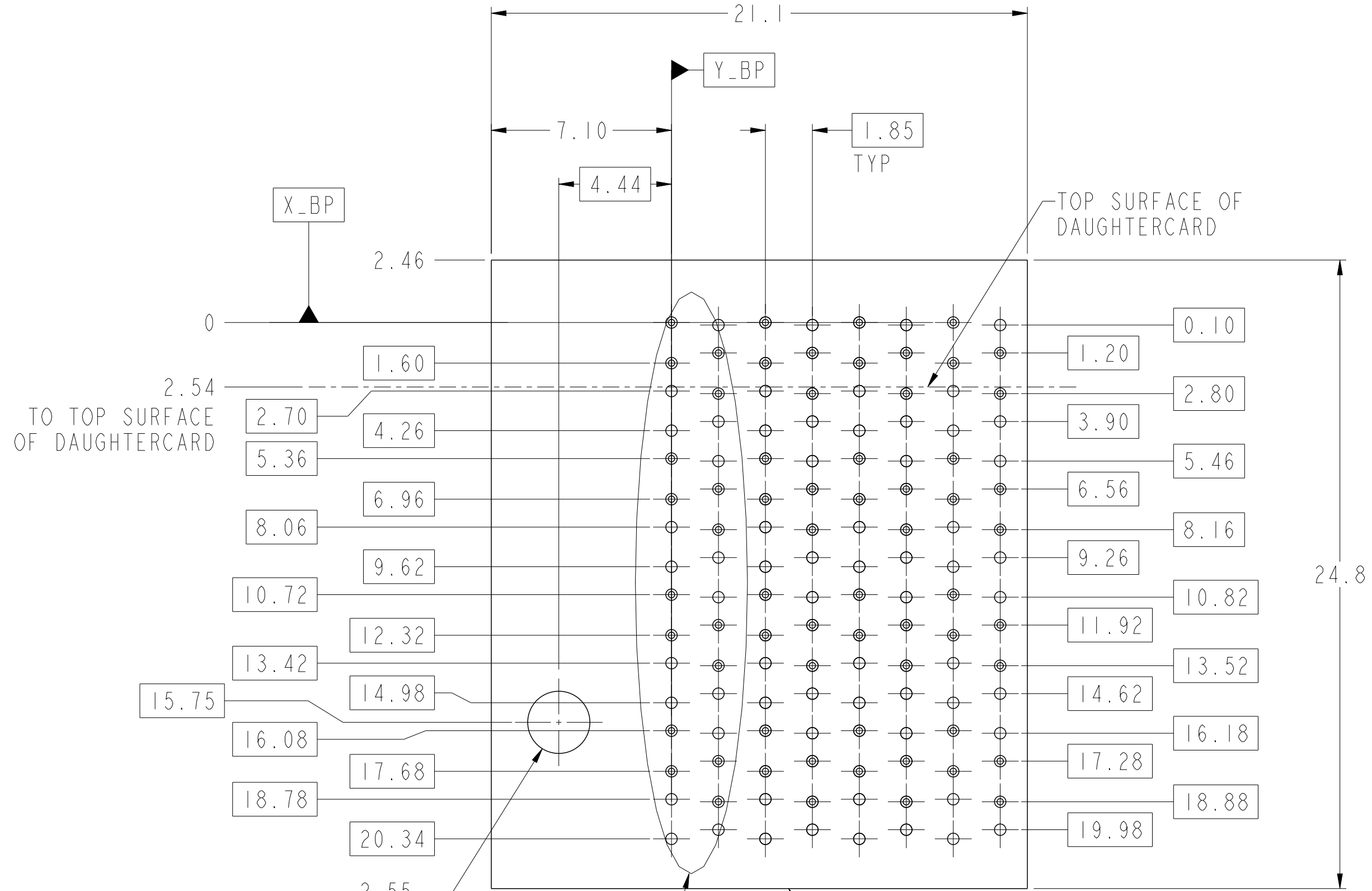

$\varnothing 0.1$ X_BP Y_BP
SEE NOTE 11 & TABLE 1

SEE DETAIL A (SHEET 8)
NOMINAL MODULE OUTLINE

PCB HOLE PATTERN
COMPONENT SIDE
SCALE 6:1

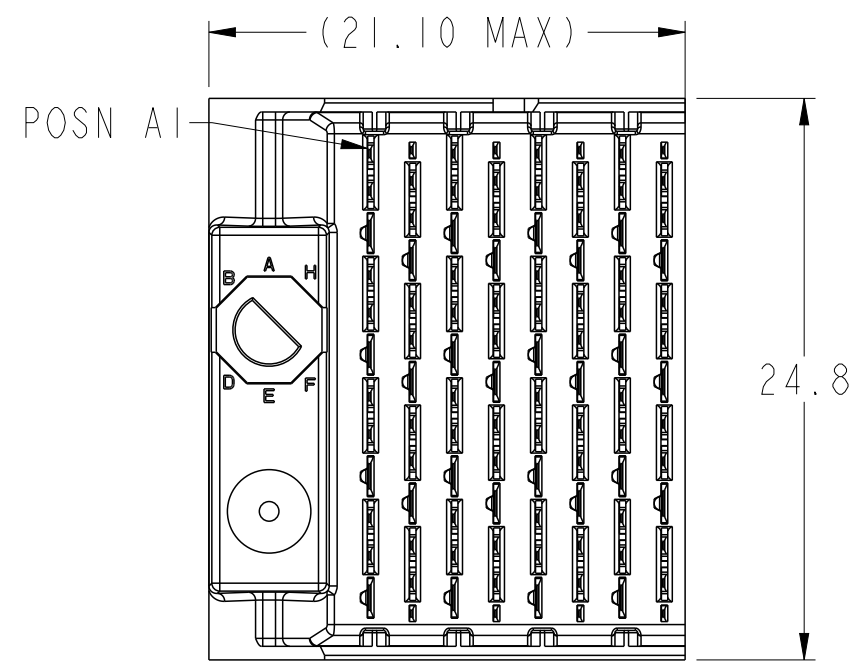

- 6.2 (4MM WIPE WIDE GROUNDS)
 - 5.2 (3MM WIPE WIDE GROUNDS)
 - 5.2 (3MM SMALL END GROUNDS)
 - 5.2 (3MM WIPE SIGNALS)
 - 4.2 (2MM WIPE SIGNALS)
- SEE P/N TREE

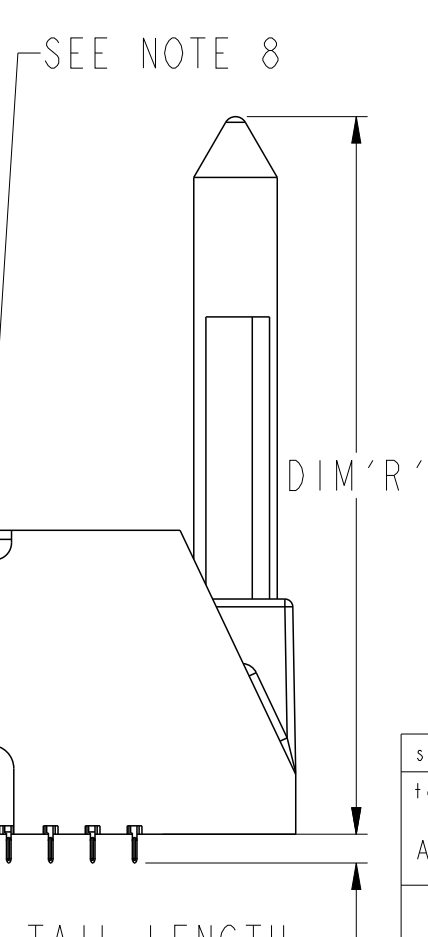
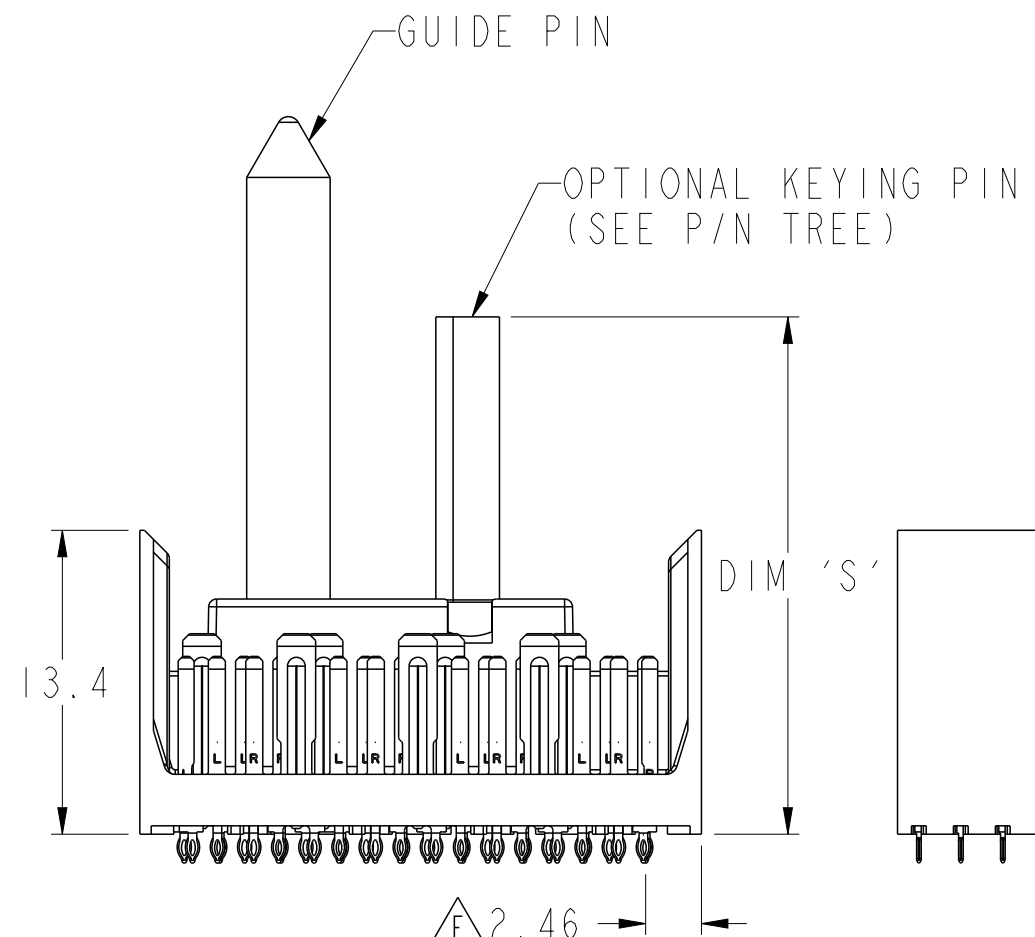
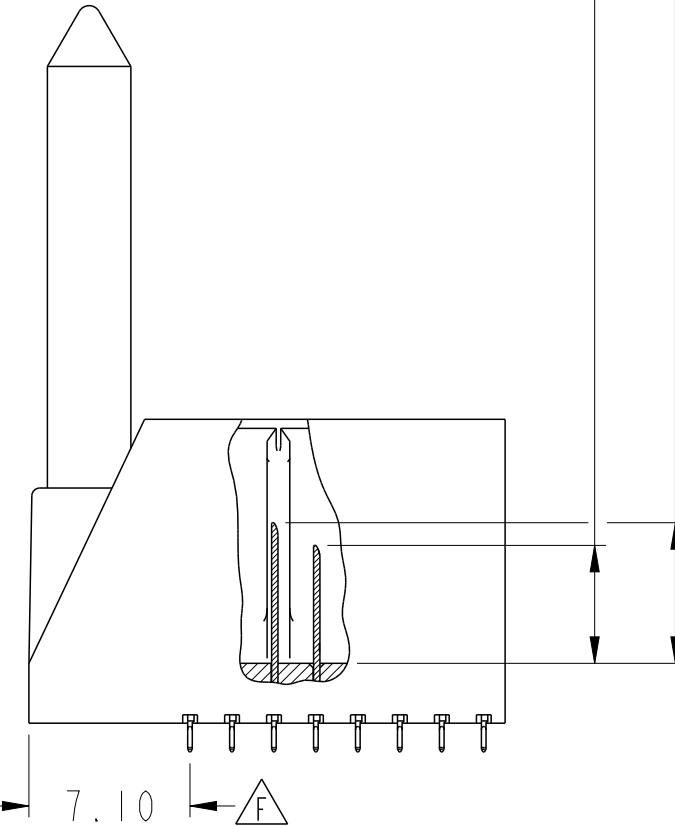

ASSEMBLY BASE CONFIGURATION END DASH NO.	GUIDE PIN	POLARIZING KEY
	DIM 'R'	DIM 'S'
-X0X	31.6mm	22.8mm
-X4X	25.7mm	20.0mm

spec ref	SEE NOTES	dr	Jim Swain	2009/07/07	projection	MM	size	A2	scale	4:1	
tolerance std	ASME Y14.5	eng	Sandar Soe	2015/06/29	chr		ecn no	ELX-S-21214-1			
	TOLERANCES UNLESS OTHERWISE SPECIFIED	appr	Chen-Hong Tan	2015/09/30	product family	XCede	rel level	Released			
surface	linear	0.X	±0.2				cat. no.	SEE P/N TREE	Product - Customer Drw	sheet 3 of 8	
		0.XX	±0.10								
		0.XXX	±0.050								
	angular	0°	±°								
		www.fci.com		TITLE		MODULE ASSEMBLY		10091777		rev	F
				cat. no.		SEE P/N TREE		Product - Customer Drw		sheet 3 of 8	

Copyright FCI. FCI

RIGHT POLARIZING/GUIDE MODULE

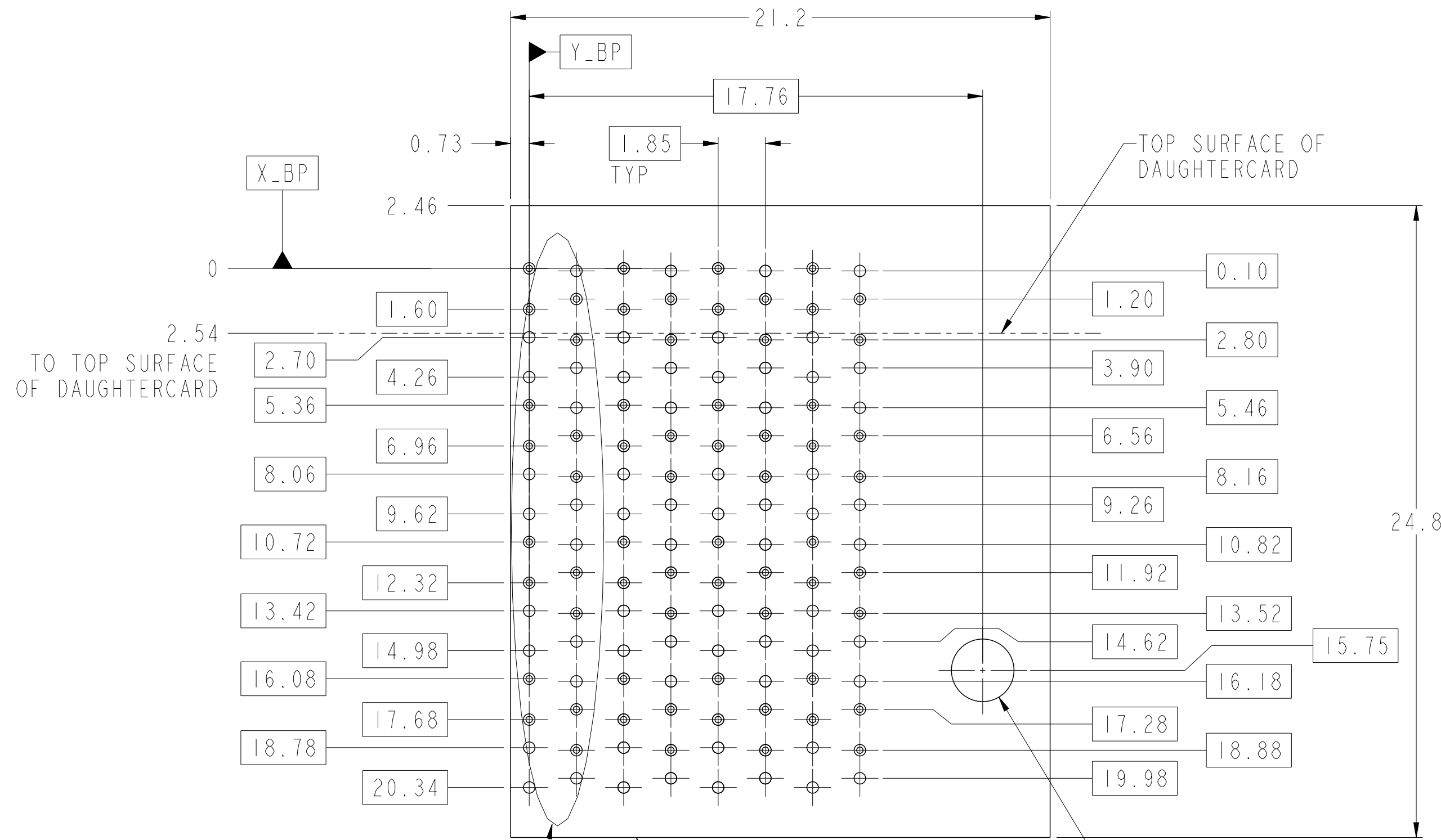
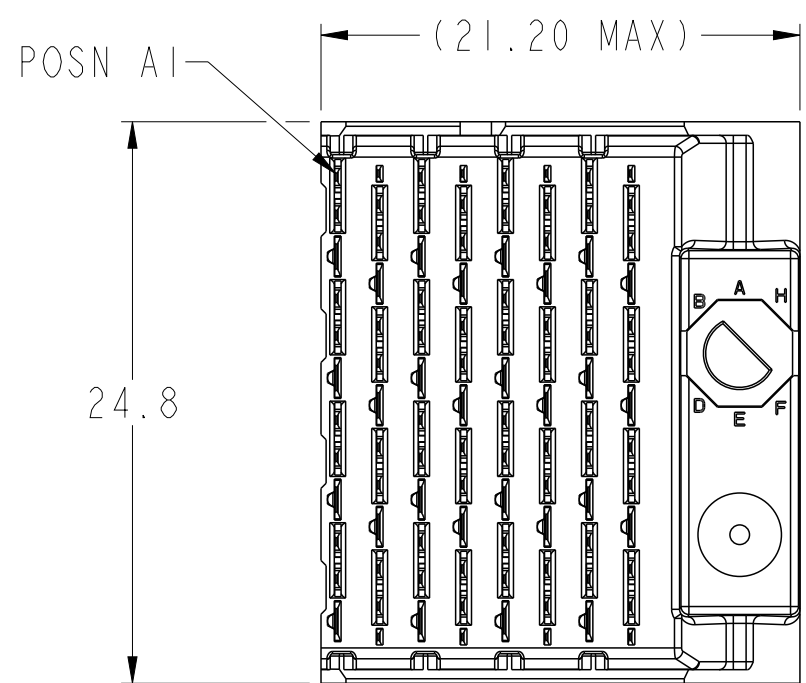
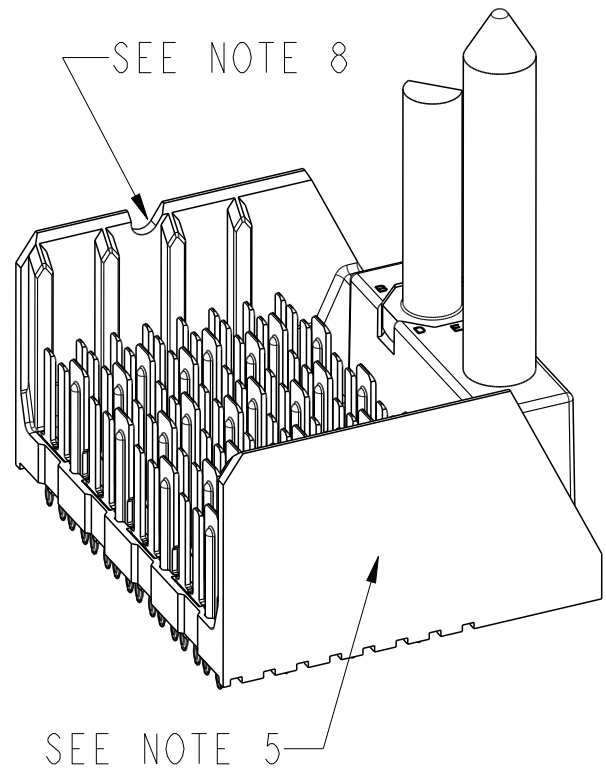

- 6.2 (4MM WIPE WIDE GROUNDS)
- 5.2 (3MM WIPE WIDE GROUNDS)
- 5.2 (3MM SMALL END GROUNDS)
- 5.2 (3MM WIPE SIGNALS)
- 4.2 (2MM WIPE SIGNALS)
- SEE P/N TREE

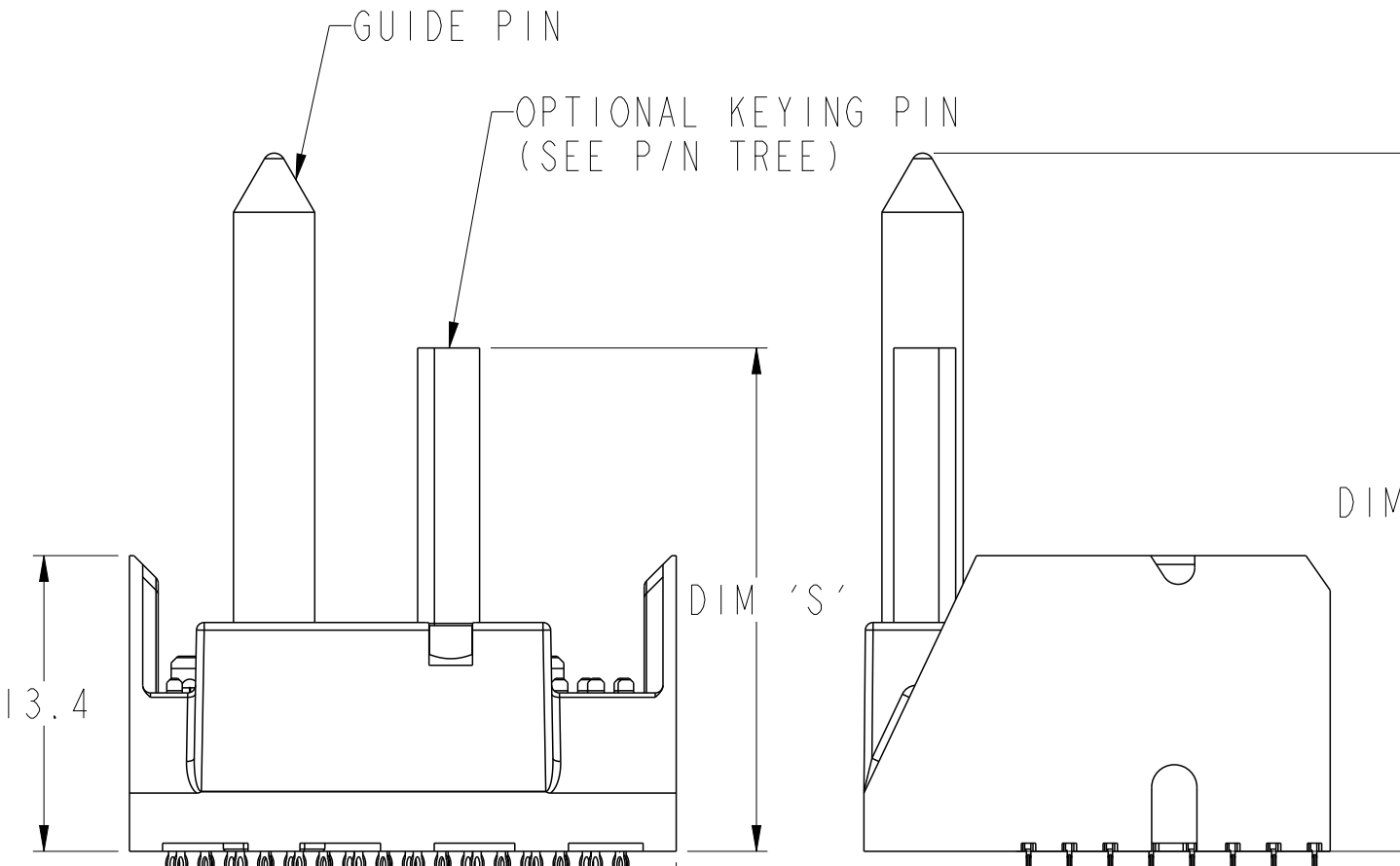
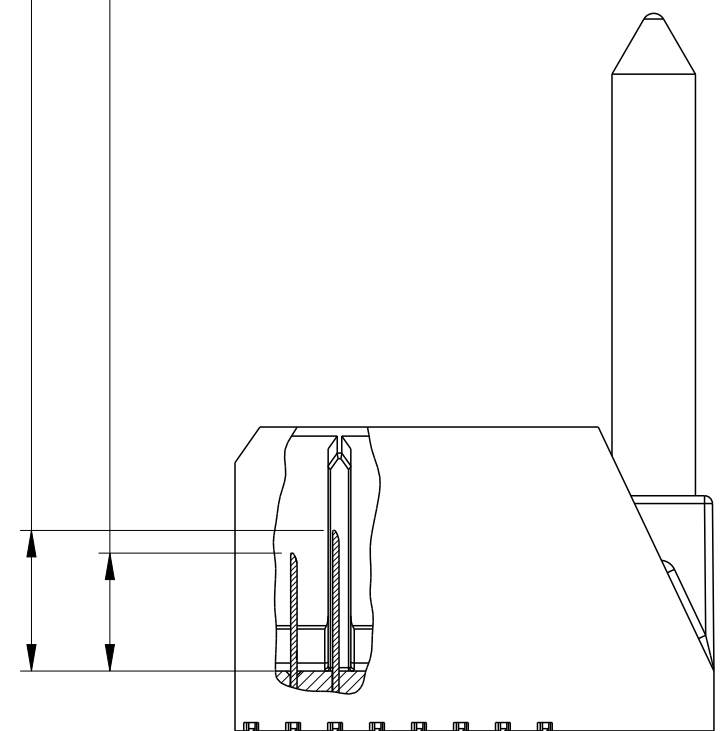

ASSEMBLY BASE CONFIGURATION END DASH NO.	GUIDE PIN	POLARIZING KEY
	DIM 'R'	DIM 'S'
-X0X	31.6mm	22.8mm
-X4X	25.7mm	20.0mm

spec ref	SEE NOTES	dr	Jim Swain	2009/07/07	projection	MM	size	A2	scale	4:1
tolerance std	TOLERANCES UNLESS OTHERWISE SPECIFIED	eng	Sandar Soe	2015/06/29	product family	XCede	ecn no	ELX-S-21214-1	rel level	Released
ASME Y14.5		chr			product family	XCede	rel level	Released		
surface	linear	0.X	±0.2		title	MODULE ASSEMBLY		cat. no. SEE P/N TREE Product - Customer Draw sheet 4 of 8	dwg no 10091777	rev F
		0.XX	±0.10							
		0.XXX	±0.050							
ASME Y14.5	angular	0°	±°	www.fci.com						

Copyright FCI.

LEFT WALL MODULE

SEE NOTE 8

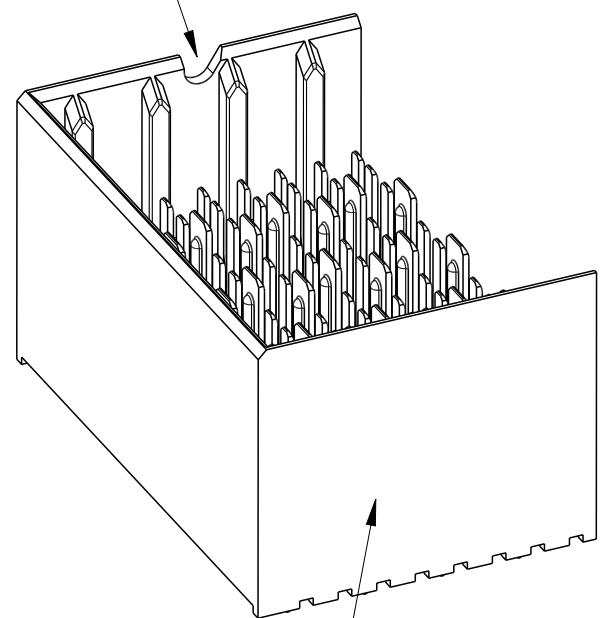

SEE NOTE 5

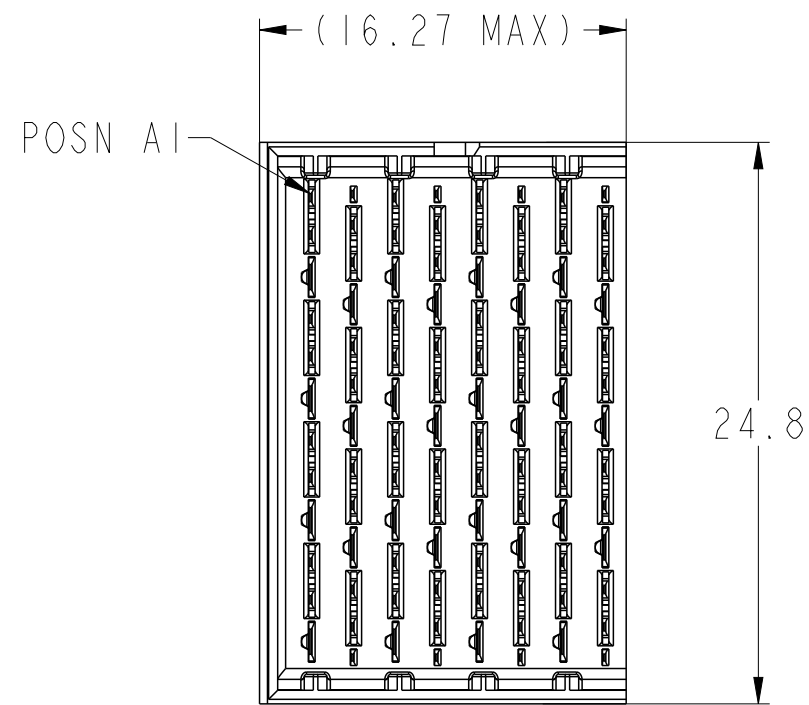

- 6.2 (4MM WIPE WIDE GROUNDS)
 - 5.2 (3MM WIPE WIDE GROUNDS)
 - 5.2 (3MM SMALL END GROUNDS)
 - 5.2 (3MM WIPE SIGNALS)
 - 4.2 (2MM WIPE SIGNALS)
- SEE P/N TREE

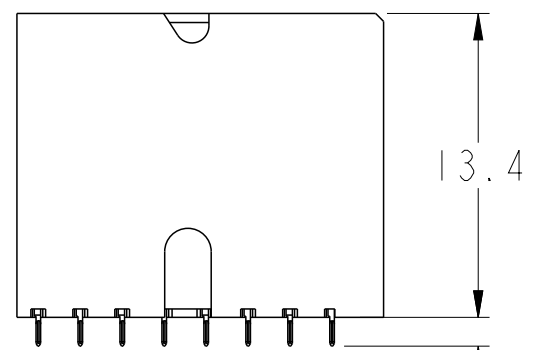
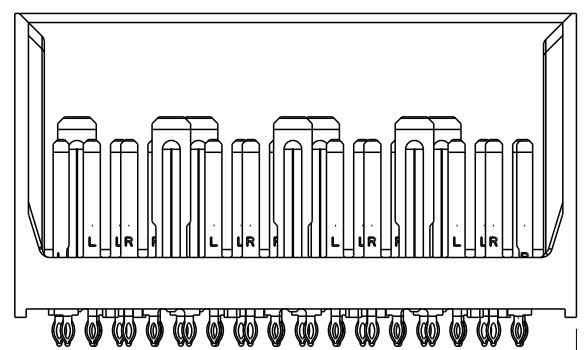
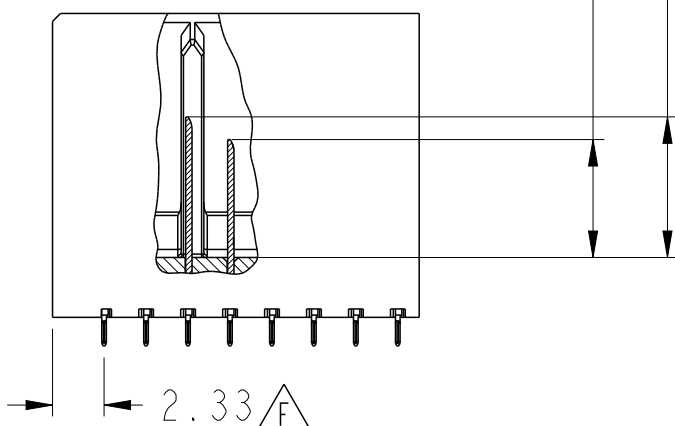

TAIL LENGTH
SEE NOTE 12

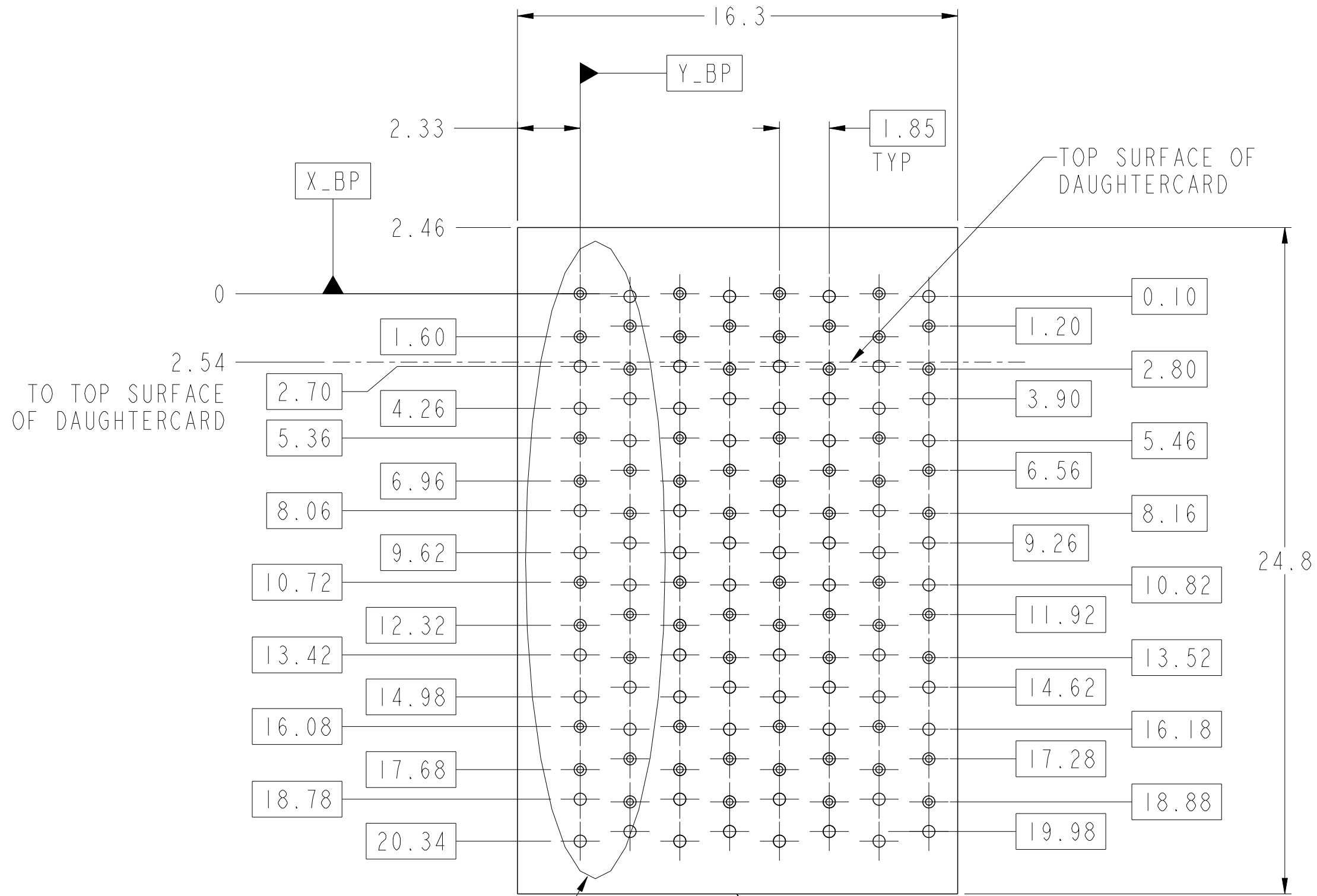

PCB HOLE PATTERN
COMPONENT SIDE
SCALE 6:1

spec ref	SEE NOTES	dr	Jim Swain	2009/07/07	projection	MM	size	A2	scale	4:1
tolerance std	ASME Y14.5	eng	Sandar Soe	2015/06/29	chr	-	ecn no	ELX-S-21214-1	rel level	Released
surface	✓	appr	Chen-Hong Tan	2015/09/30	product family	XCede	rel level	Released	dwg no	10091777
ASME Y14.5	linear	0.X	±0.2	0.XX	±0.10	0.XXX	±0.050	angular	0°	±°
				MODULE ASSEMBLY VERTICAL HEADER, 8-COLUMN, 4-PAIR		cat. no. SEE P/N TREE		Product - Customer Drw		sheet 5 of 8

RIGHT WALL MODULE

SEE NOTE 8

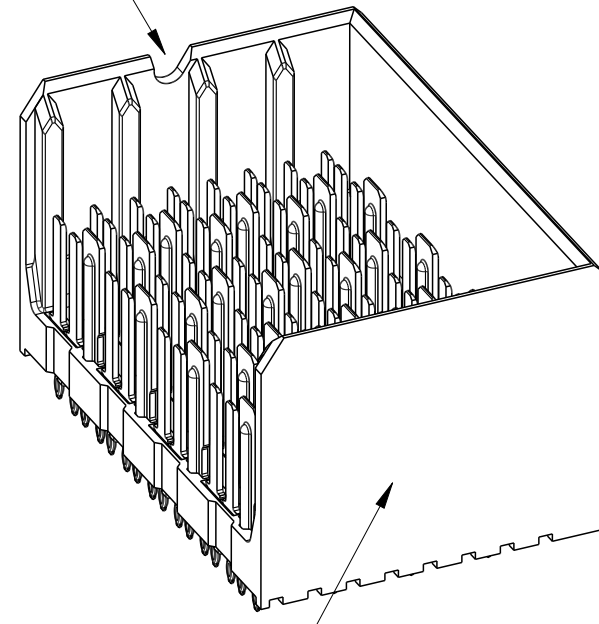

SEE NOTE 5

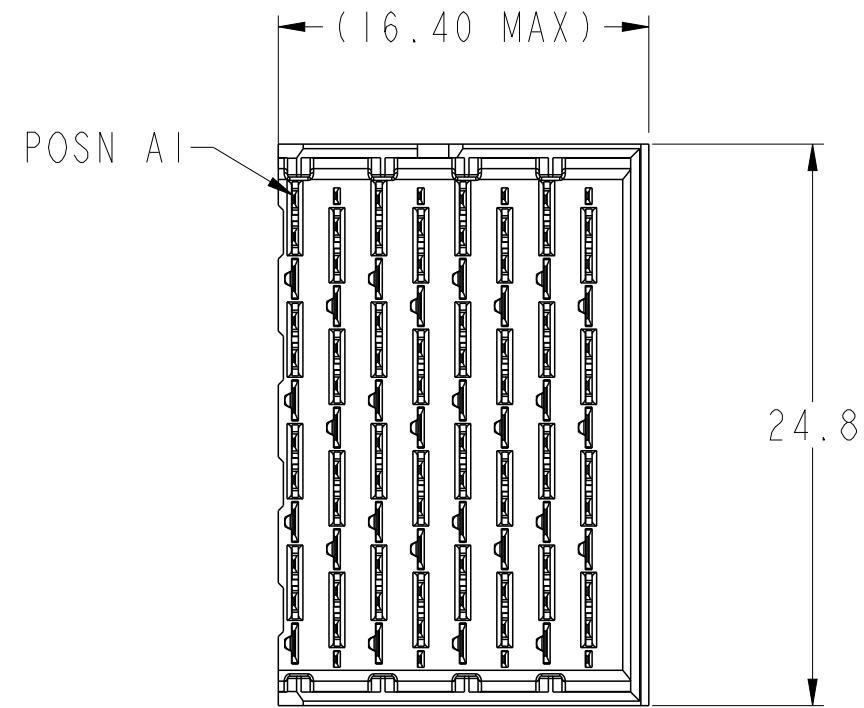

- 6.2 (4MM WIPE WIDE GROUNDS)
 - 5.2 (3MM WIPE WIDE GROUNDS)
 - 5.2 (3MM SMALL END GROUNDS)
 - 5.2 (3MM WIPE SIGNALS)
 - 4.2 (2MM WIPE SIGNALS)
- SEE P/N TREE

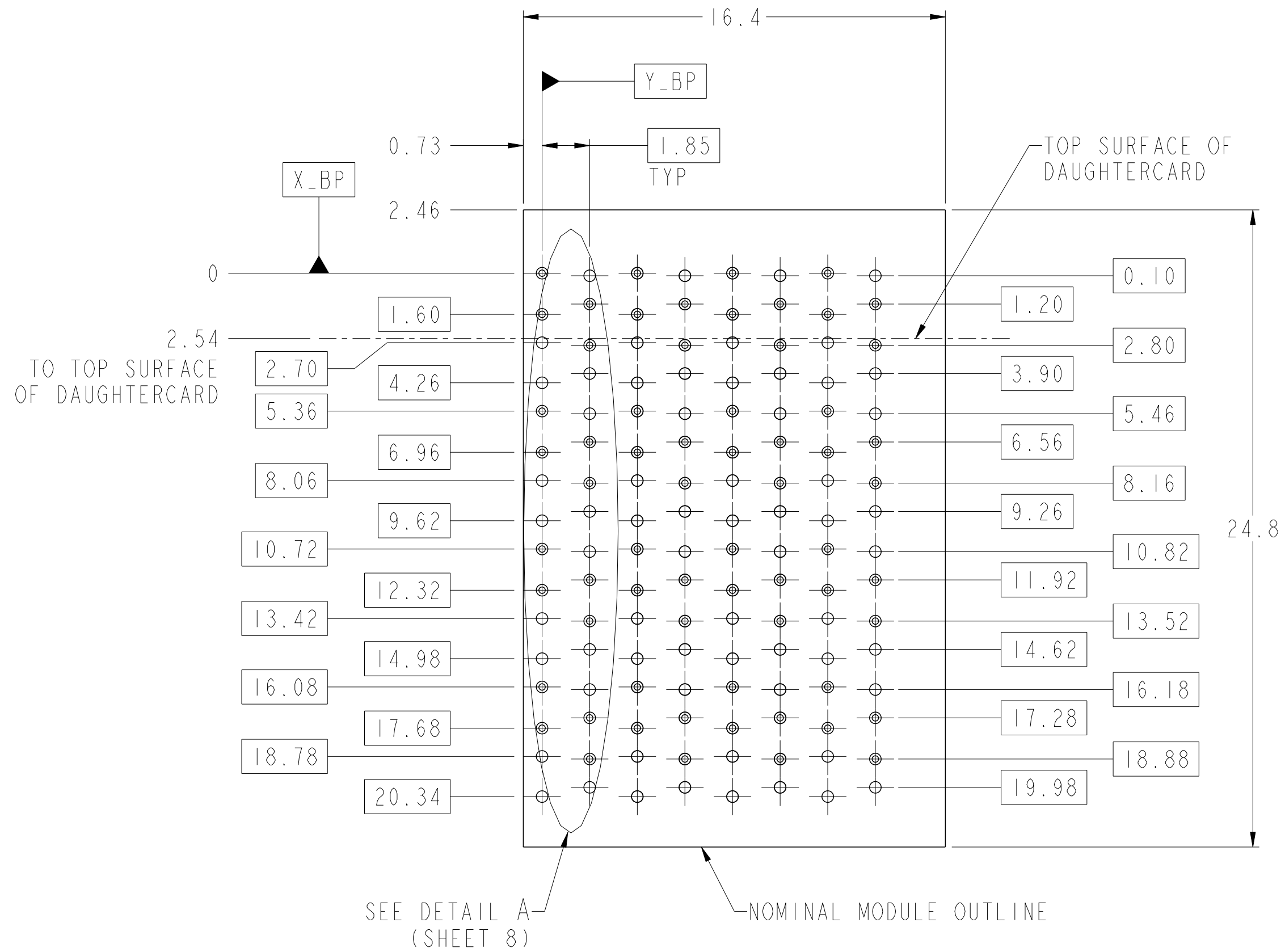
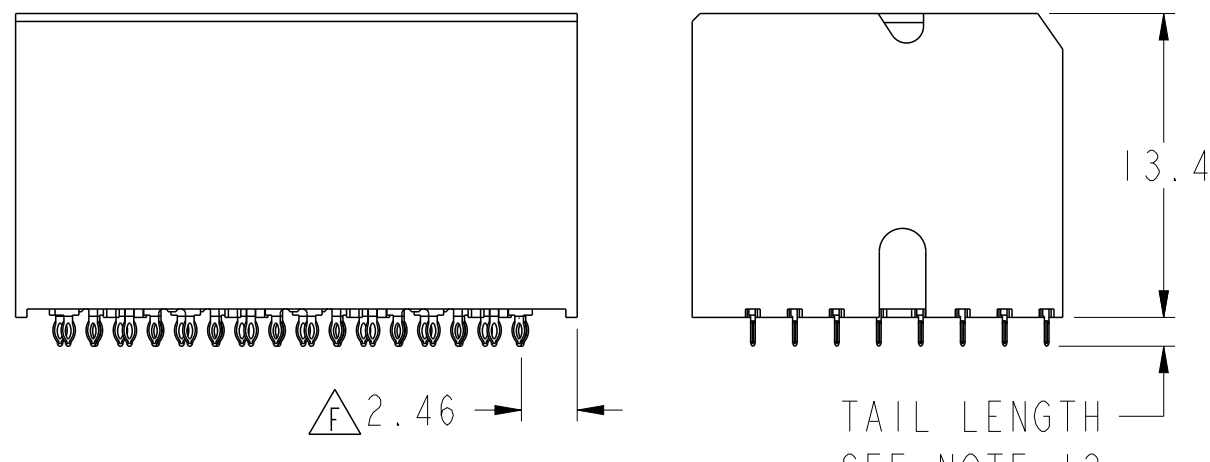
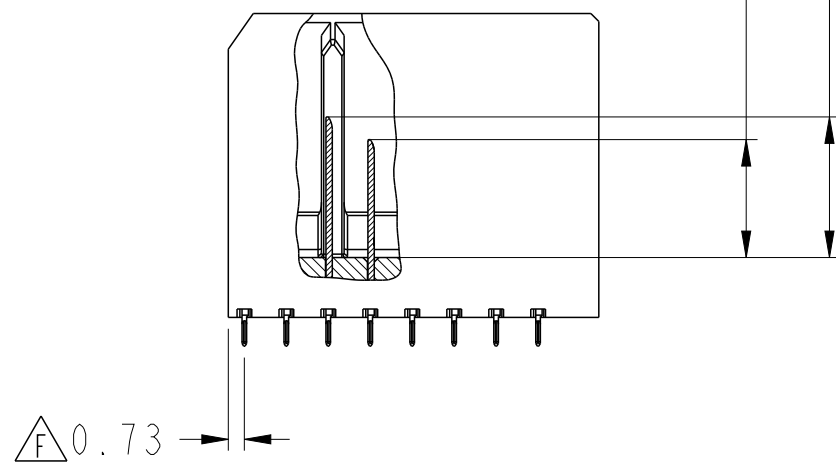

PCB HOLE PATTERN
COMPONENT SIDE
SCALE 6:1

spec ref	SEE NOTES	dr	Jim Swain	2009/07/07	projection	MM	size	A2	scale	4:1								
tolerance std	TOLERANCES UNLESS OTHERWISE SPECIFIED	eng	Sandar Soe	2015/06/29			ecn no	ELX-S-21214-1	rel level	Released								
ASME Y14.5		chr	-	app			Chen-Hong Tan	2015/09/30		product family	XCede							
surface	<table border="1"> <tr> <td>linear</td> <td>0.X</td> <td>±0.2</td> </tr> <tr> <td></td> <td>0.XX</td> <td>±0.10</td> </tr> <tr> <td></td> <td>0.XXX</td> <td>±0.050</td> </tr> <tr> <td>angular</td> <td>0°</td> <td>±°</td> </tr> </table>	linear	0.X	±0.2		0.XX	±0.10		0.XXX	±0.050	angular	0°	±°			title MODULE ASSEMBLY VERTICAL HEADER, 8-COLUMN, 4-PAIR	dwg no 10091777	rev F
linear	0.X	±0.2																
	0.XX	±0.10																
	0.XXX	±0.050																
angular	0°	±°																
ASME Y14.5		www.fci.com	cat. no.	SEE P/N TREE	Product - Customer Drw	sheet 6 of 8												



Copyright FCI.

FOUR WALL MODULE

SEE NOTE 8

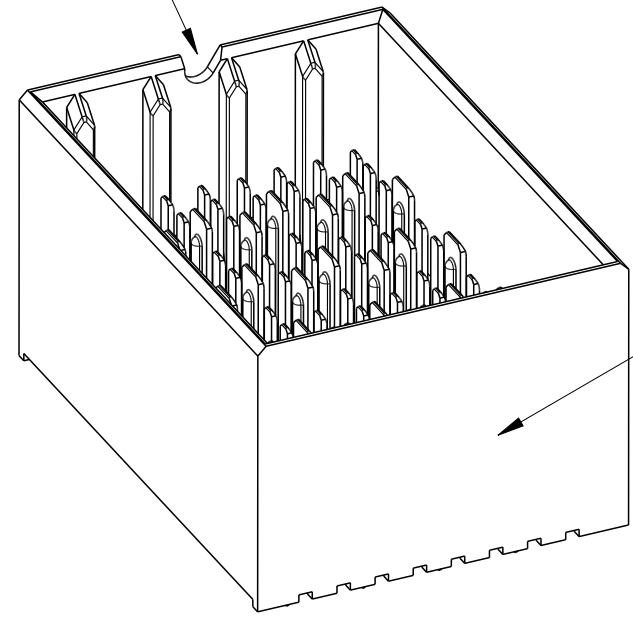

SEE NOTE 5

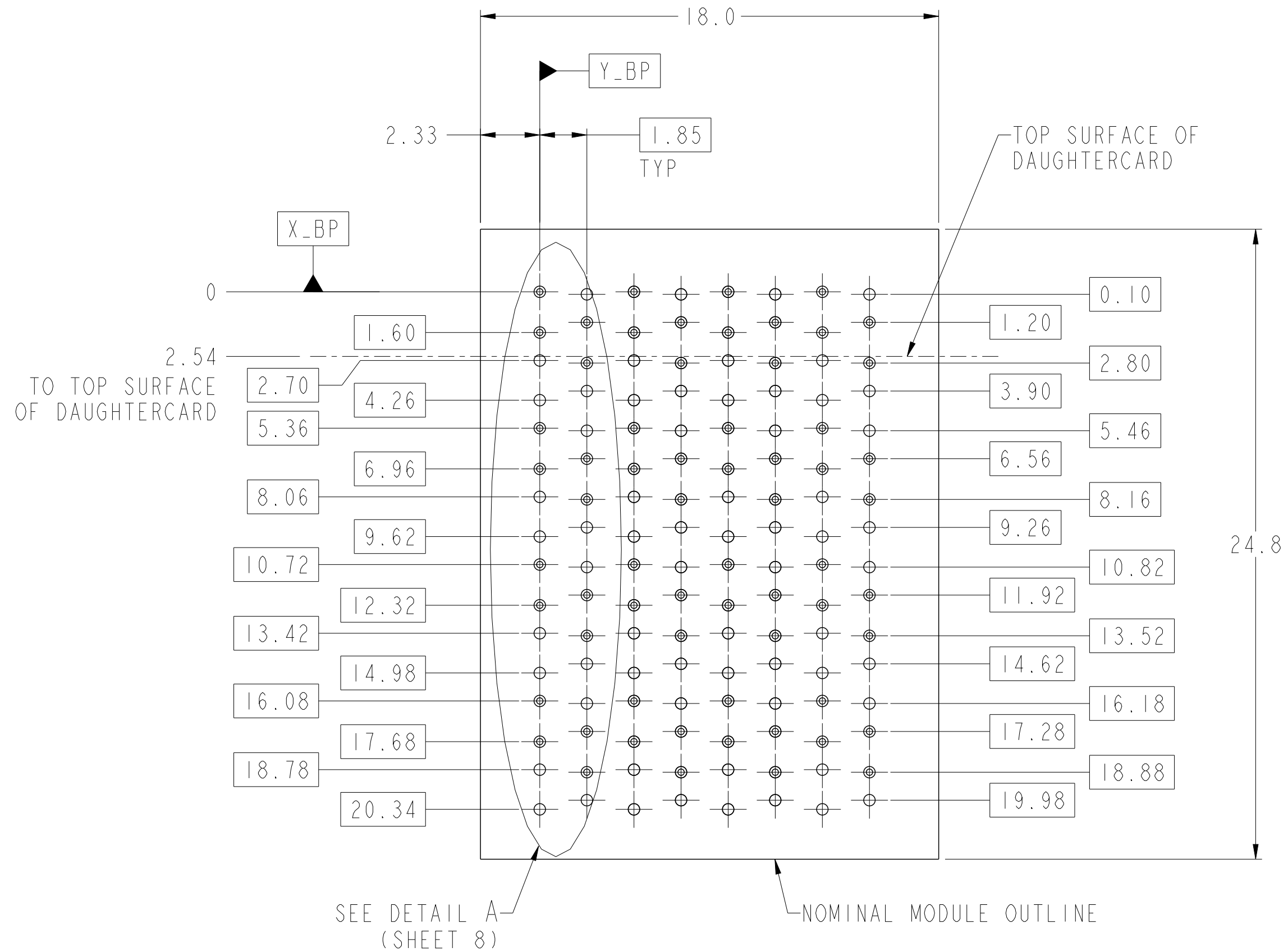
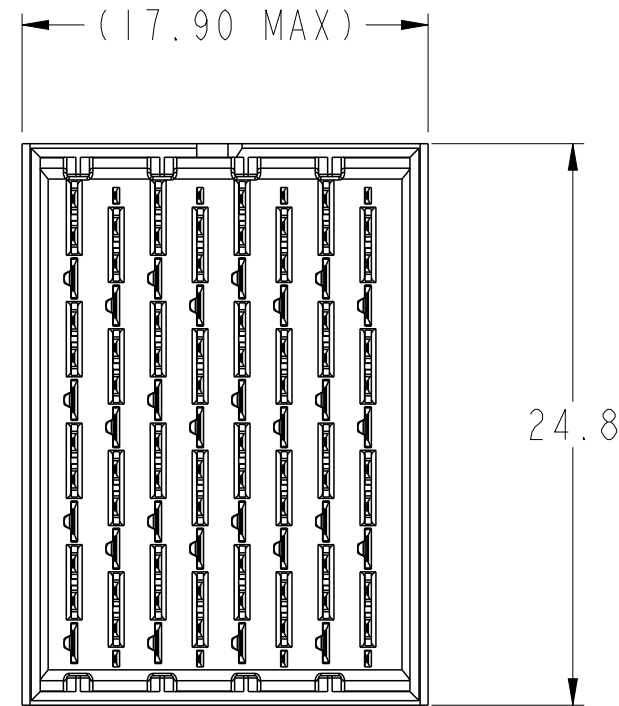

SEE DETAIL A (SHEET 8)

NOMINAL MODULE OUTLINE

PCB HOLE PATTERN
COMPONENT SIDE
SCALE 6:1

6.2 (4MM WIPE WIDE GROUNDS)
5.2 (3MM WIPE WIDE GROUNDS)

5.2 (3MM SMALL END GROUNDS)
5.2 (3MM WIPE SIGNALS)
4.2 (2MM WIPE SIGNALS)
SEE P/N TREE

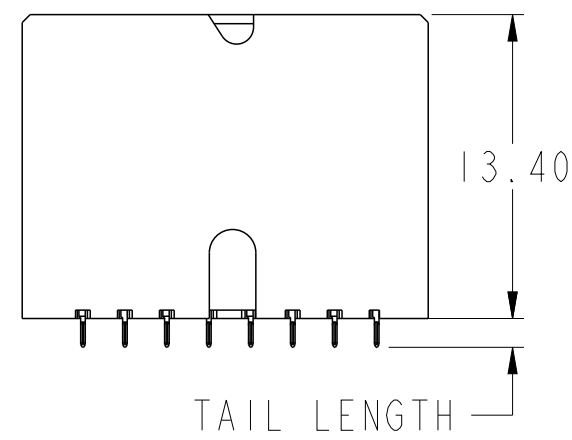
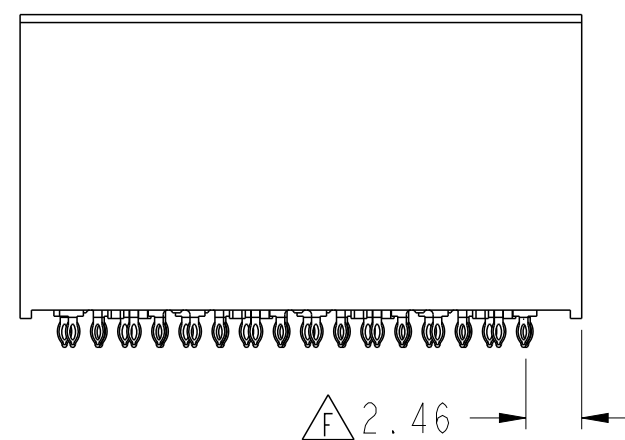
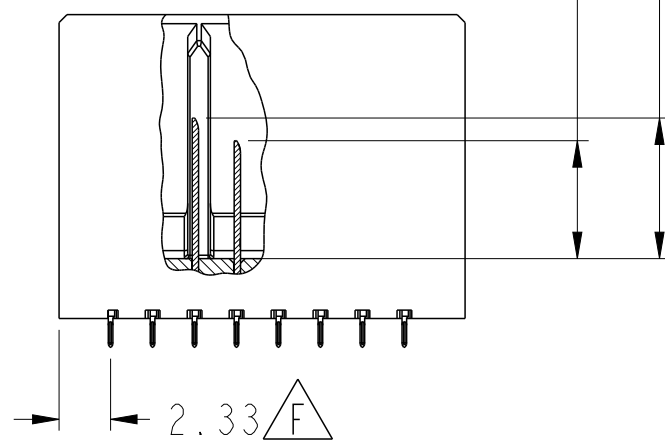

TAIL LENGTH
SEE NOTE 12

spec ref	SEE NOTES	dr	Jim Swain	2009/07/07	projection	MM	size	A2	scale	3:1										
tolerance std	TOLERANCES UNLESS OTHERWISE SPECIFIED	eng	Sandar Soe	2015/06/29			ecn no	ELX-S-21214-1	rel level	Released										
ASME Y14.5		chr		2015/09/30			product family	XCede												
surface	<table border="1"> <tr> <td>linear</td> <td>0.X</td> <td>±0.2</td> </tr> <tr> <td></td> <td>0.XX</td> <td>±0.10</td> </tr> <tr> <td></td> <td>0.XXX</td> <td>±0.050</td> </tr> <tr> <td>angular</td> <td>0°</td> <td>±°</td> </tr> </table>	linear	0.X	±0.2		0.XX	±0.10		0.XXX	±0.050	angular	0°	±°	apppr	Chen-Hong Tan	2015/09/30	product family	XCede	rel level	Released
linear	0.X	±0.2																		
	0.XX	±0.10																		
	0.XXX	±0.050																		
angular	0°	±°																		
ASME Y14.5		www.fci.com	cat. no.	SEE P/N TREE	Product - Customer Drw	sheet 7 of 8	<table border="1"> <tr> <td>dwg no</td> <td>10091777</td> </tr> <tr> <td>rev</td> <td>F</td> </tr> </table>	dwg no	10091777	rev	F									
dwg no	10091777																			
rev	F																			



Copyright FCI.

NOTES:

1. CONNECTOR MATERIALS
SHROUD: HIGH-TEMP THERMOPLASTIC, GRAY, UL94V-0
CONTACTS: HIGH PERFORMANCE COPPER ALLOY
2. CONTACT PLATING:

SEPARABLE INTERFACE: PERFORMANCE-BASED PLATING, QUALIFIED TO MEET THE REQUIREMENTS OF FCI PRODUCT SPECIFICATION GS-12-588, INCLUDING THE TELCORDIA GR-1217-CORE (NOVEMBER 1995) CENTRAL OFFICE (CO) OR UNCONTROLLED ENVIRONMENT (UE) TEST SEQUENCE AS NOTED IN P/N TREE.

PRESS-FIT TAILS: TIN OVER NICKEL (LF), OR TIN-LEAD ALLOY OVER NICKEL (NON-LF). SEE P/N TREE.
3. PRODUCT SPECIFICATION: GS-12-588
4. APPLICATION SPECIFICATION: GS-20-121
5. PRODUCT MARKING (PART NUMBER AND LOT CODE) ON THESE SURFACES.
6. HOUSING MUST WITHSTAND EXPOSURE TO 260°C PEAK TEMPERATURE FOR 40 SECONDS IN A CONVECTION, INFRA-RED, OR VAPOR-PHASE REFLOW OVEN.
7. PACKAGING MEETS GS-14-920 LEAD-FREE LABELING SPECIFICATION.
8. NOTCH INDICATES "ROW A" SIDE OF CONNECTOR.
9. SEE APPLICATION SPECIFICATION FOR ROUTING GUIDELINES, ADDITIONAL PTH GUIDELINES, MATED DIMENSIONS, GUIDE PN SELECTION, ETC.
10. SCREW IS OPTIONAL AND ENGAGES WITH BOTTOM OF GUIDE-PIN FROM BENEATH THE PCB FOR ADDITIONAL GUIDE-PIN SUPPORT.
11. OPTIONAL HOLE LOCATION FOR GROUNDED PIN OR ADDITIONAL GUIDE-PIN SUPPORT. SEE TABLE 1 ON SHEET 1 FOR ADDITIONAL DETAILS.
12. TAIL LENGTH=1.3mm FOR $\varnothing 0.55$ [0.0217"]COMPLIANT PIN DRILL
TAIL LENGTH=1.5mm FOR $\varnothing 0.45$ [0.0177"]COMPLIANT PIN DRILL
13. A \triangle SYMBOL WILL BE NEXT TO ANY DIMENSION, VIEW OR NOTE THAT HAS BEEN MODIFIED WITH THE CURRENT DRAWING REVISION.

TABLE 3: PTH AND PAD SIZES WITH REFERENCE TO COMPLIANT PIN DRILL		
COMPLIANT PIN DRILL	PTH	PAD
$\varnothing 0.55$ [0.0217"]	$\varnothing 0.45 \pm 0.05$	$\varnothing 0.85$
$\varnothing 0.45$ [0.0177"]	$\varnothing 0.36 \pm 0.05$	$\varnothing 0.75$

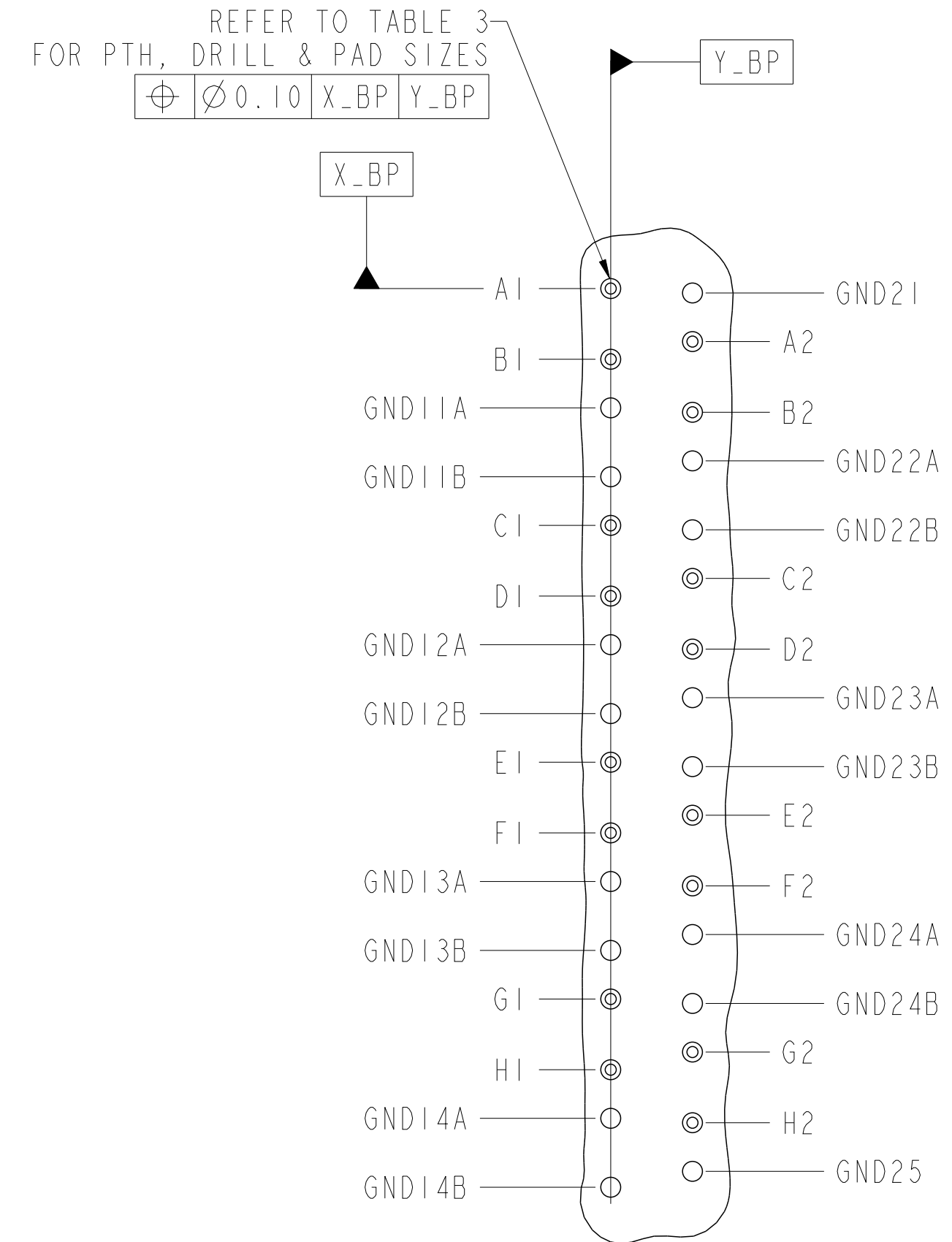

DETAIL A
SCALE 8:1

spec ref	SEE NOTES	dr	Jim Swain	2009/07/07	projection	MM	size	A2	scale	4:1								
tolerance std	TOLERANCES UNLESS OTHERWISE SPECIFIED	eng	Sandar Soe	2015/06/29			ecn no	ELX-S-21214-1										
ASME Y14.5		chr		appr			Chen-Hong Tan	2015/09/30	product family	XCede	rel level	Released						
surface	<table border="1"> <tr> <td>linear</td> <td>0.X</td> <td>± 0.2</td> </tr> <tr> <td></td> <td>0.XX</td> <td>± 0.10</td> </tr> <tr> <td></td> <td>0.XXX</td> <td>± 0.050</td> </tr> <tr> <td>angular</td> <td>0°</td> <td>\pm</td> </tr> </table>	linear	0.X	± 0.2				0.XX	± 0.10		0.XXX	± 0.050	angular	0°	\pm		MODULE ASSEMBLY VERTICAL HEADER, 8-COLUMN, 4-PAIR	cat. no. SEE P/N TREE
linear	0.X	± 0.2																
	0.XX	± 0.10																
	0.XXX	± 0.050																
angular	0°	\pm																